

2022

## DECLARATION OF PERFORMANCE (DOP)

### Category I Aggregate Concrete Masonry Units

No. MU008

1. Unique identification of Product type:

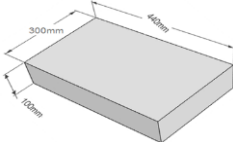
Description	Mean Strength N/mm <sup>2</sup>	Dimensions (Length – Width- Height) mm		
		Length	Width	Height
18 x 12" Foundation Blocks	10.5N/mm <sup>2</sup> (Capped) 	440	300	100

**2. Type batch or serial number or any other element allowing identification of the construction product as required under Article 11 (4) of the CPR:**

The production details are traceable by the delivery note.

- 3. Intended use/s:** IS EN 771-3 2011 & BS EN 771-3 2011 - Aggregate Concrete Masonry Units intended for use in load bearing or non-load bearing buildings and civil engineering end uses.
- 4. Manufacturer:** Robinson Concrete , 86 Cumber Road, Claudy Co Londonderry BT47 4JA.
- 5. Authorised representative:** Mr. Scott Robinson
- 6. System of AVCP:** System 2+
- 7. Harmonised standard:** EN 771-3 Specification for Masonry units Part 3: Aggregate Concrete Masonry Units (Dense & Lightweight aggregates)
- 8. Notification certification body:** NSAI

9. Declared performance:

Essential characteristics	Declared Performance	Technical Reference
Dimensional Tolerance	D1	SR325
Configuration	Group 1	SR325
Gross Density (Direct Airborne Sound Insulation)	2050 kg/m <sup>3</sup>	EN 772-13
Compressive Strength (Mean)	10.5 N/mm <sup>2</sup> (Capped)	EN 772-1 & SR325
Unit Category	Category 1	Table 14 SR325
Direction of Load	Perpendicular to bed faces	
Dimensional Stability – Moisture Movement	<0.6mm/m	EN 772-14
Reaction To Fire	Class A1	Technical Guidance Document B-Fire Safety
Durability Against Freeze Thaw	<p>Suitable for use in:</p> <p><b>Masonry Condition Situations A1 &amp; A2</b> as outlined in Table 14 of S.R. 325:2013 + A2:2018. (Work below or near external ground level) - MX2. 1/2.2</p> <p>-Mean compressive strength<math>\geq</math>7.5 N/mm<sup>2</sup></p> <p>-Aggregate in accordance with I.S. EN 12620 and S.R 16</p> <p>-Mortar Strength Class M4 for A1 or M6 for A2</p>	SR325

Shear Bond Strength	0,15N/mm <sup>2</sup>	(Tabulated Value)
Flexural Bond Strength	0,5N/ mm <sup>2</sup>	(Tabulated Value)
Water Absorption	<10g/m <sup>2</sup> s	EN 772-11
Water Vapour Permeability	5/15u	EN 1745 Annex A (Tabulated Value)
Thermal Resistance	1.11 W/mK <sub>(λ10, dry, )</sub>	(Tabulated Value)
*Dangerous Substances	NPD	

**10.**

Signed for and on behalf of Robinson Concrete by:

\_Scott Robinson\_\_\_\_\_

Place & date of issue:

\_Claudy 23<sup>rd</sup> September 2022\_\_\_\_\_